

ISL2853x_63xEV2Z User's Guide

Introduction

The ISL2853x_63xEV2Z board allows simple evaluation of the ISL2853x and ISL2863x 5V Zero Drift Programmable Gain Instrumentation Amplifiers. The board is designed with all necessary components to easily connect the high performance amplifier to an external signal. It can operate from a single supply +2.5V to +5.5V or dual supply of ±1.25V to ±2.75V.

The ISL2853x is a differential input, single ended output instrumentation amplifier. The ISL2863x is a differential input, differential output instrumentation amplifier, suited to drive differential ADCs. The amplifier can be programmed with 9 gain settings over a range of 1V/V to 1,000V/V using only two logic inputs. Refer to the device [datasheet](#) for more information on programming the gain of the instrumentation amplifier.

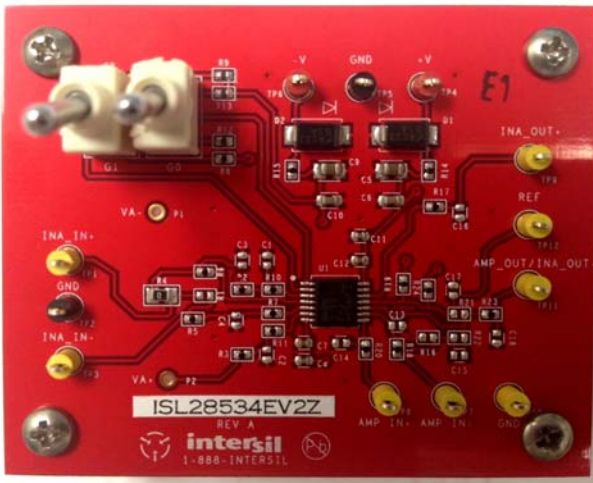

Reference Documents

- ISL28533, ISL28534, ISL28535, ISL28633, ISL28634, ISL28635 [datasheet](#)
- Application Note [AN1853](#) Strain Gauge DAQ On USB Stick

High Precision Amplifier

The ISL2853x and ISL2863x family of instrumentation amplifiers offer very low offset, noise and offset drift using Zero Drift amplifier circuitry. With precision matched internal gain resistors these amplifiers offer high gain accuracy while reducing the need for additional external resistors in applications that need different gain settings. Combined with Rail-to-Rail Input and Output, the ISL2853x and ISL2863x instrumentation amplifiers are ideal for single supply low noise, high precision amplification and signal conditioning.

Input Common Mode Range

The ISL2853x and ISL2863x are designed using the 3 op-amp topology that has a first stage differential amplifier (Gain) and second stage difference amplifier (Common Mode Rejection). Since the common mode voltage is buffered in the first stage and eliminated in the second stage it is important not to saturate the output of the first stage. An input signal with high V_{CM} will have limited gain range before saturation. Refer to device [datasheet](#) for more information on V_{CM} vs V_{OUT} limitations of the instrumentation amplifier.

VA+ and VA- Pin Outs

Unique to the ISL2853x and ISL2863x instrumentation amplifiers are the outputs of the first stage differential amplifier pinned out of the device, called VA+ and VA- for the INA+ and INA- inputs respectively. As the common mode voltage is buffered the VA pins can be used to sense the input V_{CM} . This is important for sensor applications that may want to track the V_{CM} voltage for sensor health monitor. Refer to device [datasheet](#) for more information on monitoring the input V_{CM} .

Getting Started

- Connect power supply to V+ and V- pins. Single supply +2.5V to +5V. Dual supply ±1.25V to ±2.5V.
- Connect voltage to REF pin for setting output reference. The board has 1kΩ resistors to V+ and V- to preset the output reference voltage to mid scale of supply voltage.
- Set gain of instrumentation amplifier by setting the G0 and G1 gain switches into proper state as shown in Table 2.
- Connect differential input voltage to left side of the evaluation board.
- Measure output voltage of instrumentation amplifier on right side of the evaluation board.
- *IMPORTANT* For the ISL2853xEV2Z boards, the additional Op Amp inputs (AMP IN+ and AMP IN-) are floating. If the op amp is not used, for proper operation place a 0Ω at R22 and terminate AMP IN+ to ground through C14 or TP8.

TABLE 1. KEY PERFORMANCE SPECIFICATION

DEVICE #	VALUE	UNITS
Input Offset Voltage	5	μV
Input Offset Drift	50	nV/°C
Gain Accuracy	0.05	%
Gain Drift	10	ppm/°C
0.1Hz to 10Hz Noise Pk to Pk	0.25	μV _{p-p}
Input Noise Density, f = 1kHz	20	nV/√Hz
CMRR	120	dB
Gain Bandwidth Product	2	MHz

Application Note 1880

TABLE 2. PROGRAMMABLE GAIN SWITCHING

G1	G0	GAIN		
		ISL28533 ISL28633	ISL28534 ISL28634	ISL28535 ISL28635
0	0	1	1	1
0	Z	2	2	100
0	1	4	10	120
Z	0	5	50	150
Z	Z	10	100	180
Z	1	20	200	200
1	0	40	300	300
1	Z	50	500	500
1	1	100	1000	1000

TABLE 3. ORDERING INFORMATION

BOARD PART NUMBER	OUTPUT	GAIN RANGE
ISL28533EV2Z	Single Ended	1 to 100
ISL28534EV2Z		1 to 1,000
ISL28535EV2Z		1 to 1,000
ISL28633EV2Z	Differential	1 to 100
ISL28634EV2Z		1 to 1,000
ISL28635EV2Z		1 to 1,000

ISL2853x_63xEV2Z Evaluation Board Layout

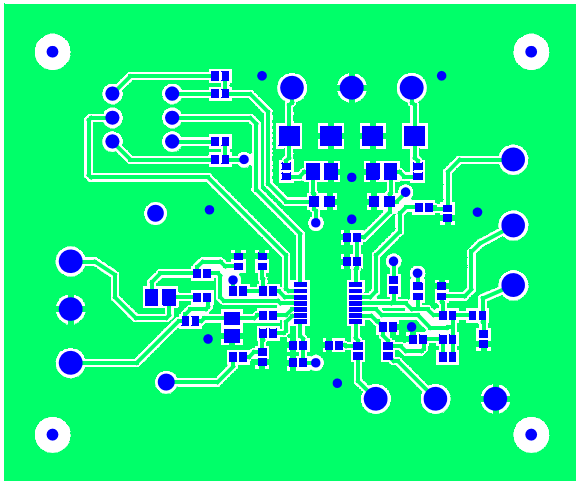

FIGURE 1. TOP LAYER PCB

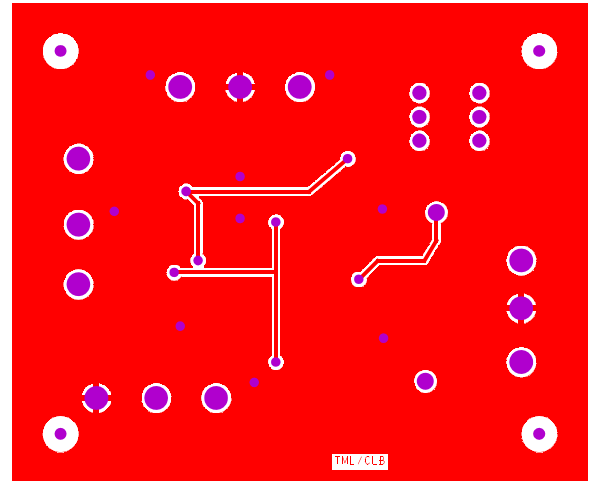

FIGURE 2. BOTTOM LAYER PCB

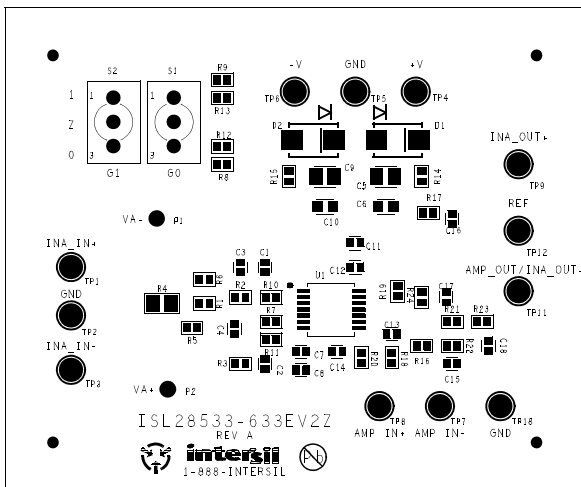

FIGURE 3. ASSEMBLY TOP LAYER

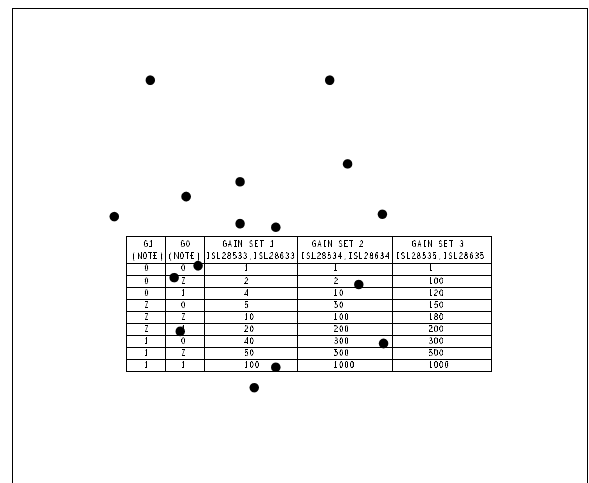

FIGURE 4. BOTTOM LAYER SILKSCREEN

ISL2853x_63xEV1Z Schematic

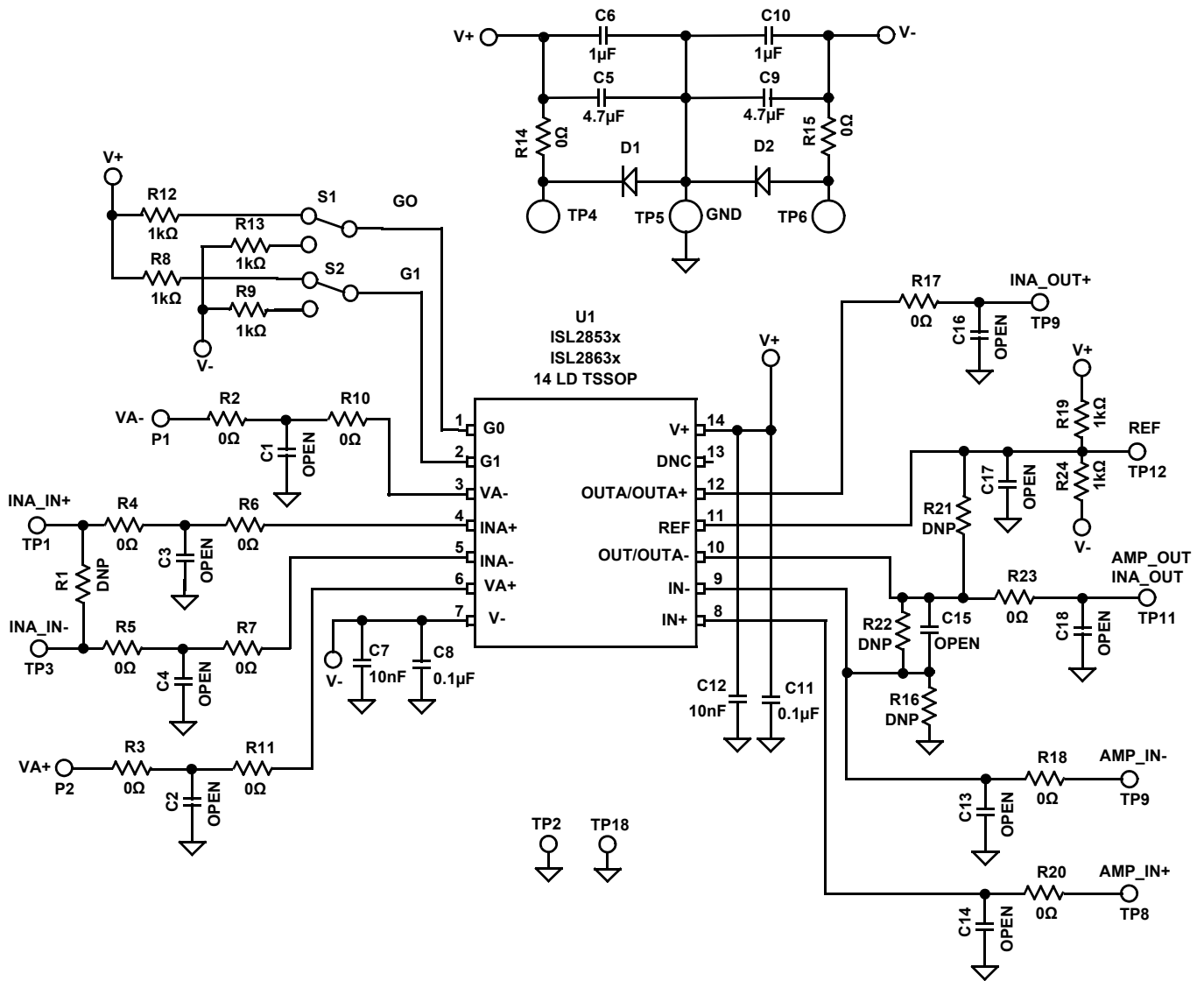

FIGURE 5. ISL2853x_63x EVALUATION BOARD SCHEMATIC

Application Note 1880

TABLE 4. BILL OF MATERIALS

PART #	REF DES	DESCRIPTION	MANUFACTURER
ISL28533FVZ ISL28534FVZ ISL28535FVZ ISL28633FVZ ISL28634FVZ ISL28635FVZ	U1	Programmable Zero Drift Instrumentation Amplifier	Intersil
GRM155R71E103KA01	C7, C12	0.01 μ F SMD Capacitor; 10%; 25V	Murata
H1044-00104-16V10	C8, C11	0.1 μ F SMD Capacitor; 10%; 16V	Generic
DNP	C1-C4, C13-C18	DNP; Placeholder	Generic
H1045-00105-16V20	C6, C10	1 μ F SMD Capacitor; 20%; 16V	Generic
H1046-00475-10V20	C5, C9	4.7 μ F SMD Capacitor; 20%; 10V	Generic
S1A	D1, D2	1A SMD Rectifier Diode	DIODES-INC
H2510-00R00-1/16W	R2, R3, R5-R7, R10, R11, R14, R15, R17, R18, R20, R23	0 Ω SMD Resistor; 1%; 1/16W	Generic
H2510-01001-1/16W1	R8, R9, R12, R13, R19, R24	1k Ω SMD Resistor; 1%; 1/16W	Generic
DNP	R1, R16, R21, R22	DNP; Placeholder	Generic
H2512-00R00-1/10W	R4	0 Ω SMD Resistor; 1%; 1/10W	Generic
ET03SD1CBE	S1, S2	SEALED SUBMINIATURE TOGGLE SWITCH	ITT CANNON - C&K

Intersil Corporation reserves the right to make changes in circuit design, software and/or specifications at any time without notice. Accordingly, the reader is cautioned to verify that the Application Note or Technical Brief is current before proceeding.

For information regarding Intersil Corporation and its products, see www.intersil.com